

## Q179C,D Miniature Gas Pilot Burner Assemblies

*The Q179C,D Miniature Gas Pilot Burner Assemblies are applicable to proving the pilot flame on industrial, commercial gas or gas pilot ignited oil burners.*

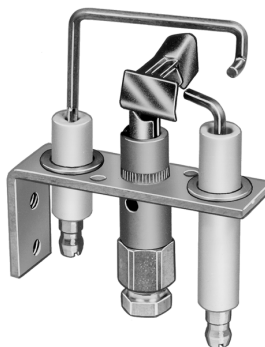

**Q179C  
(FLAME ROD  
AND IGNITION  
ELECTRODE)**

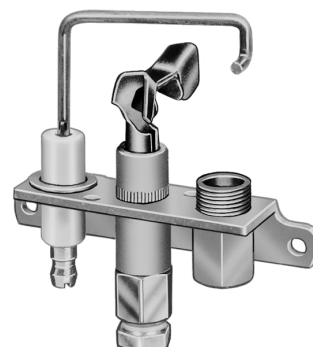

**Q179D  
(FLAME ROD AND  
THERMOCOUPLE  
ADAPTER)**

- Q179C,D assemblies are compatible with flame safe-guard controls utilizing the rectification principle of flame proving.
- Q179C is a gas pilot assembly that incorporates ignition and flame electrodes. Is suitable for applications requiring interrupted or intermittent spark ignited gas pilots.
- Q179C may be used with the Q624A Solid State Ignition Transformer (Interrupted Pilot), 22042, 101079 Ignition Transformers or equivalents.
- Q179D has a flame electrode (rod) and a thermocouple adapter and is suitable for continuous pilot applications. Can be used with Q340A Thermocouple or Q313A,B Thermopile Generator.
- Primary aerated type pilot burner with a stainless steel target to stabilize the flame and provide the proper flame electrode (rod) area to ground area ratio to generate an optimum flame signal.
- High temperature Kanthal electrode(s) are mounted in ceramic insulators.
- Side or end mounting brackets available.
- Dual and single wing burner targets available.
- Q179C,D are miniature functional replacements for the Q179A,B respectively.
- Flame electrode (rod) ignition electrode and insulators are factory positioned and adjusted for proper operation. Field adjustments are not required.

### CONTENTS

Specifications .....	2
Ordering Information .....	2
Installation .....	4
Checkout .....	5

# Specifications

**MODELS:**

**Q179C** Miniature Gas Pilot Burner Assembly. Includes ignition electrode for intermittent or interrupted ignition applications; use with Q624 solid state spark generator or other suitable ignition transformer. Includes natural gas orifice. LP gas orifice available (see Accessories).

**Q179D** Miniature Gas Pilot Burner Assembly. Thermocouple adapter is provided in place of ignition electrode for use with Q340 Thermocouple or Q313 Thermopile in continuous pilot applications. Includes natural gas orifice.

**MOUNTING:** See Fig. 1 for mounting options and burner target configurations. See Fig. 2 for mounting dimensions.

**BURNER:** Primary aerated. Stainless steel target provides proper flame ground. Properly positioned flame electrode (and ignition electrode with Q179C) are provided. The pilot burner has three target configurations—dual wing, single wing right-hand, and single wing left-hand (Fig. 1). Single wing targets are for use with Q179C only.

**TARGET WINGSPAN:** Single wing—13/16 inch [21 mm]; Dual wing—1 inch [25 mm], except 2 inches [51 mm] on Q179C1074 and Q179D1032.

**TYPE OF GAS:** Natural; for LP gas order LP orifice separately (see Accessories).

**NATURAL GAS ORIFICE SIZE:** .026 inch [.66 mm] diameter for dual wing target or .024 inch [.61 mm] diameter for single wing target.

**ELECTRODE(S):** Kanthal, maximum temperature 2200° F [1204° C].

**ELECTRODE INSULATOR(S):** Ceramic.

**MOUNTING DIMENSIONS:** See Fig. 2.

**APPROVALS:**

Underwriters Laboratories Inc. component recognized:  
 File No. MH9928.

Canadian Standards Association Certified: Master File  
 No. LR-95329-1.

American Gas Association design certified: Report No.  
 G-140-1-4.

Industrial Risk Insurers acceptable.

**THERMAL RATING:** See Fig. 3.

**INLET FITTINGS:** 1/4 inch compression coupling factory-installed on all models.

**THERMOCOUPLE FOR Q179D;** Order a Q340 Thermocouple or Q313 Thermopile.

**REPLACEMENT PARTS:**

**Orifices—**

Part no. 388146AF, orifice spud fitting assembly, for natural gas single wing target, .024 inch [.61 mm] diameter.

Part no. 388146AG, orifice spud fitting assembly, for natural gas double wing target, .026 inch [.66 mm] diameter.

**Fig. 1—Mounting options and burner target configurations.**

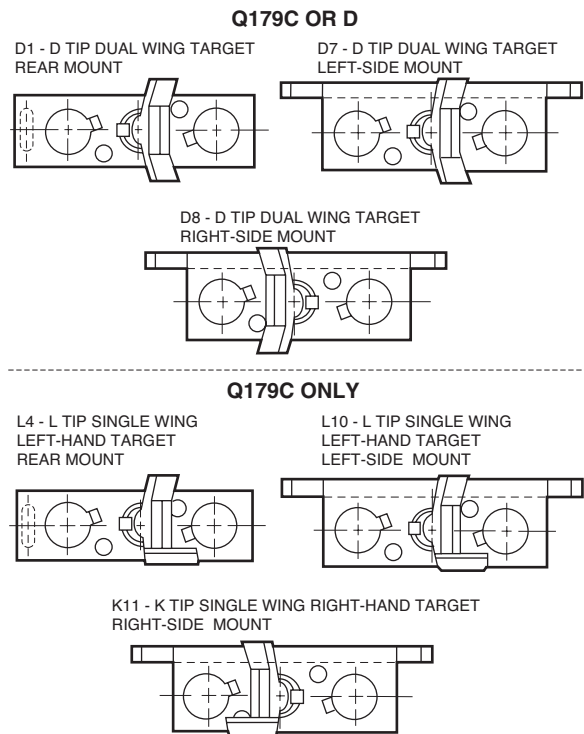

NOTE: MOUNTING NUMBER DESIGNATES BOTH BRACKET TYPE AND TARGET CONFIGURATION. DESCRIPTION REFERENCE POINT IS FROM BACK OF BURNER TARGET. M3054A

# Ordering Information

When purchasing replacement and modernization products from your Authorized Flame Safeguard Distributor or Wholesaler, refer to the TRADELINE Catalog or price sheets for complete ordering number, or specify—

1. Model number.
2. Type of burner target and mount by mount number.
3. Q340 Thermocouple or Q313 Thermopile for Q179D.
4. Accessories, if desired.

If you have additional questions, need further information, or would like to comment on our products or services, please write or phone:

1. Your local Honeywell Residential and Building Controls Division Sales Office (check white pages of phone directory).
2. Residential and Building Controls Division Customer Satisfaction  
 Honeywell Inc., 1885 Douglas Drive North  
 Minneapolis, Minnesota 55422 (612) 542-7500

(In Canada—Honeywell Controls Limited, 740 Ellesmere Road, Scarborough, Ontario M1P 2V9) International Sales and Service offices in all principal cities of the world.

**Fig. 2—Approximate mounting dimensions in inches [millimeters] and arrangement of parts.**

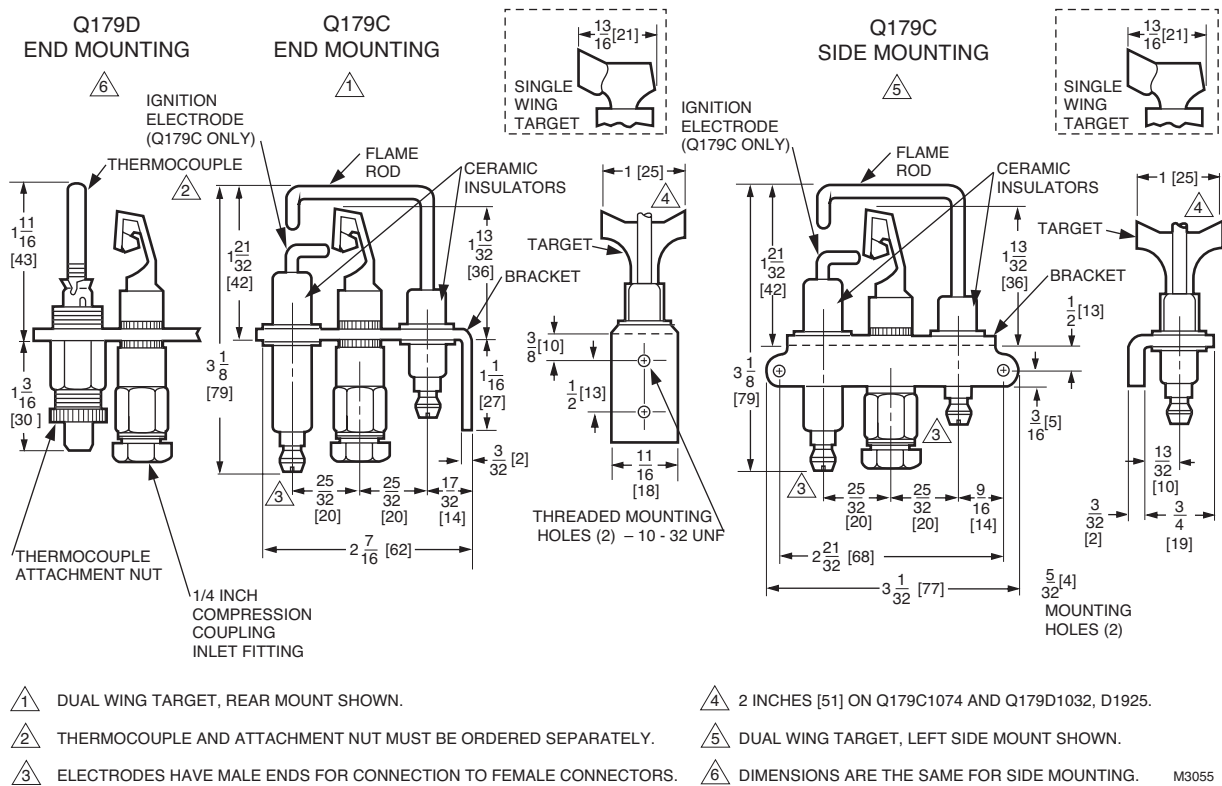

**ACCESSORIES:**

- High Temperature Cable—over 125° F [52° C].
- Flame Rod Lead—part no. R1298020 (specify length), rated at 400° F [204° C].
- Ignition Lead—part no. R1061012 (specify length), rated at 350° F [177° C].
- LP Orifice—Orifice spud fitting assembly for both single and dual wing burner targets, part no. 388146KD, .016 inch [.41 mm] diameter.
- Electrode Connectors—not furnished with Q179C,D. Use straight or right angle automotive type spark plug type electrode connectors (two required). Part no. 37356, female Rajah Connector, can be used as

alternate (two required).

**NOTE:** All models have an identification number (not O.S. number) stamped in the bracket to indicate (1) model number, (2) burner tip style, (3) mounting bracket style, and (4) date code. The following complete Order Specification numbers cross reference to the metal-stamped identification numbers on the devices.

**Fig. 3—Component maximum temperature ratings.**

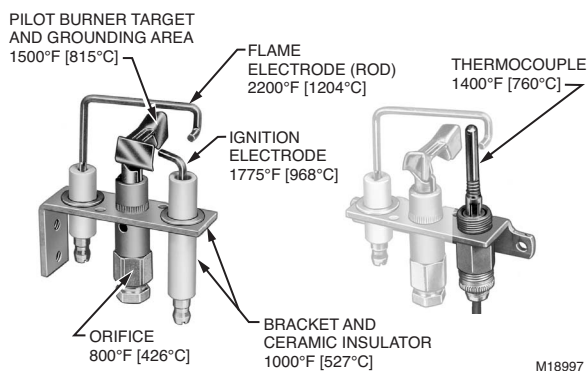

O.S. Number	Identification Number <sup>a</sup>		
Q179C1009	Q179C	D1	XXXX
Q179C1025	Q179C	L4	XXXX
Q179C1033	Q179C	D7	XXXX
Q179C1041	Q179C	D8	XXXX
Q179C1058	Q179C	L10	XXXX
Q179C1066	Q179C	K11	XXXX
Q179C1074 <sup>b</sup>	Q179C	D1	XXXX
Q179C1082	Q179C	K11	XXXX
Q179D1008	Q179D	D1	XXXX
Q179D1016	Q179D	D7	XXXX
Q179D1024	Q179D	D8	XXXX
Q179D1032 <sup>b</sup>	Q179D	D1	XXXX
Q179D1057	Q179D	L10	XXXX
Q179D1925 <sup>b</sup>	Q179D	D1	XXXX

<sup>a</sup> XXXX will be the date code.

<sup>b</sup> With 2 inch [51 mm] wingspan dual wing target.

# Installation



## CAUTION

1. Installer must be a trained, experienced flame safeguard control technician.
2. Turn off the main gas supply to the equipment before beginning the installation.
3. Disconnect the power supply to the flame safeguard control before beginning the installation. More than one disconnect may be involved.
4. Conduct a thorough operational checkout when the installation is completed.

Follow instructions provided by burner manufacturer if available. If no instructions are furnished, use the following recommendations.

### MOUNTING

The Q179C,D side and end mounting brackets have two holes for mounting. These two holes are threaded in the end mounting bracket to accept 10-32 UNF (not furnished) screws.

The pilot must be mounted rigidly in an upright or nearly upright position. The angle from vertical must not exceed 15 degrees. The pilot should be positioned where it will ignite the main burner under all normal inlet pressures and ambient conditions.

All models have a factory-installed 1/4 inch compression coupling inlet fitting.

### GAS PRESSURE REGULATION

Use a pressure regulator in the line supplying the Q179C,D pilot. Do not exceed a maximum inlet gas pressure of 8 inches water column. The minimum inlet gas pressure must be two inches water column to assure reliable lightoff of the main burner.

### INSTALL THE Q179C,D

Install the pilot so pilot flame has full contact with the gas stream from the main burner heads or jets. The pilot should fire in the same direction as the draft at the mounting point, rather than at right angles to the draft. Position the pilot burner below or behind the main burner so that the burner frame and refractory will help protect the pilot from radiant heat. Locating the pilot in the secondary airstream will also provide considerable cooling.



## CAUTION

The flame electrode (rod), ignition electrode and insulators are NOT field adjustable. Any attempt at adjustment may result in cracked insulators, which will require complete pilot burner changeout.

### DO NOT INSTALL THE Q179C,D

- where ambient temperatures exceed those specified.
- where excessive draft turbulence can deflect the pilot flame away from the main burner or flame electrode.

- where the ignition electrode is within arcing distance of any metal other than the pilot burner target.
- where the flame electrode contacts any metal part of the installation.
- where the flame electrode is closer than 1 inch [25.4 mm] from a radiant refractory.

### INSTALL THERMOCOUPLE OR THERMOPILE (Q179D)

Screw the thermopile into thermocouple adapter and tighten (Fig. 4).

Fig. 4—Thermocouple installed on Q179D.

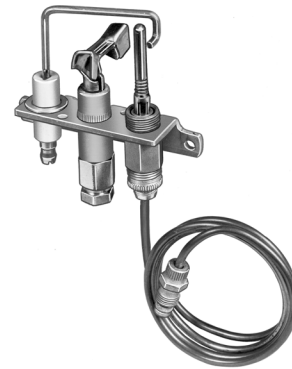

### WIRING



## CAUTION

Disconnect power supply before connecting wiring to prevent electrical shock or equipment damage. There may be more than one disconnect involved. All wiring must comply with applicable codes and ordinances.

High tension wire, of a type found acceptable by a nationally recognized testing agency, must be used for the wiring to the ignition electrode. High tension wires should be rated electrically equivalent to type GTO-10 and should be good for the temperature and humidity encountered in the application. If the ignition lead is exposed to temperatures in excess of 125° F [52° C], use Honeywell Ignition Cable, rated at 350° F [177° C], or equivalent. See Accessories.

For wiring between the F terminal of the flame safeguard control and the flame electrode, use wire with moisture-resistant insulation. Number 14 single-conductor TW wire is adequate. However, those portions of the leadwire exposed to temperatures over 125° F [52° C] should also be heat-resistant. For both heat- and moisture-resistant applications, use part no. R1298020 Cable, rated at 400° F [204° C] continuous duty, or equivalent.

Run a ground wire from the pilot burner to the relay to assure a permanent ground. Run ground wire from pilot burner bracket to G terminal on flame safeguard control. Do not rely on the pilot gas line for adequate ground connection.

# Checkout

If draft conditions are severe, it may be necessary to install a sheet metal baffle to reduce excess draft turbulence at the pilot flame.

## CAUTION

Check to ensure the main valve opens only when the pilot flame is strong enough to ignite the main burner. Perform the Pilot Turndown Test as described in the Honeywell flame safeguard control instructions.

The proper pilot burner orifice must be selected for the gas being used (natural, LP gas) so that the pilot burns with a medium hard flame. This type of flame provides the maximum flame signal.

The flame safeguard control relay will *chatter* if excess secondary air velocity or a severe draft condition causes the pilot flame to make intermittent contact with the flame electrode (rod) or grounding bracket.

The performance of the pilot assembly can be determined by measuring the flame signal developed with the pilot operating. The flame signal (current/voltage) measurement requires using an appropriate volt-ohmmeter.

Most existing Honeywell flame safeguard controls incorporate a flame current jack in the control plug-in amplifier or in the control itself. The flame current measurement can be made with a Honeywell W136A volt-ohmmeter, which has a zero to 25 microampere dc scale (see Fig. 5). With the W136A Selector Switch positioned to the zero to 25 microampere dc scale, connect the meter leads to the two ends of the meter connector plug, positive (red, +) to positive, negative (black, -) to negative. The Meter Connector Plug part no. 196146 is provided with the W136A Meter. If a W136A Meter or Connector Plug is not available, a dc ammeter with a zero to 25 microampere scale can be wired in series with the F lead of the flame detector circuit. A minimum flame current of 2.0 microamperes is considered acceptable.

The Honeywell BCS 7700 and 7800 SERIES Flame Safeguard Control flame signals are measured in dc volts. A volt-ohm meter with a zero to 5 or 10 Vdc scale and a minimum sensitivity of 20,000 ohm/volt is suggested for BCS 7700 control flame signal measurements while a one megohm/volt meter is recommended for 7800 SERIES control measurements. The flame signal voltages are measured as illustrated in Figs. 6 and 7. The minimum acceptable flame signal voltage for the BCS 7700 Controls is 2.2 Vdc (maximum expected is 4.98 Vdc). The minimum acceptable flame signal voltage for the 7800 SERIES Controls is 1.25 Vdc (maximum expected is 5.0 Vdc).

If a Q340 Thermocouple is used with the Q179D, the open circuit output of the thermocouple should be at least 18 mV

with a pilot inlet gas pressure of 2.5 inches water column.

If the minimum acceptable steady flame signals cannot be obtained, check the following:

- Cracked insulators.
- Loose or poor electrical connections.
- Improper grounding of pilot burner.
- Incorrect type of wire.
- Wet, moist wire insulation to flame electrode (rod).
- Insufficient combustion air.
- Excessive air movement (draft) across pilot burner target.
- Gas pressure outside the recommended range.

**Fig. 5—Measuring the microamp flame signal.**

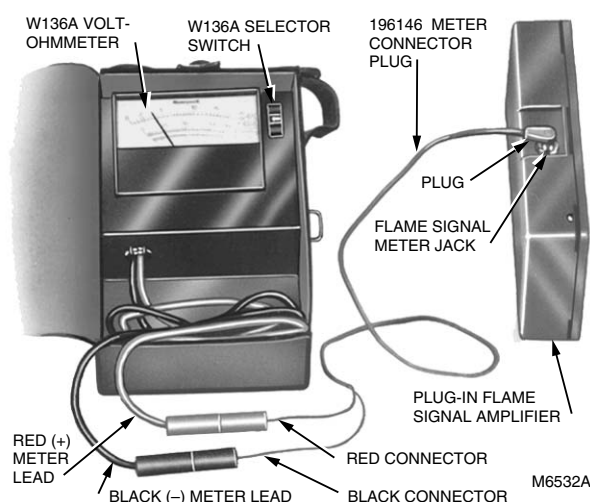

**Fig. 6—Measuring the BCS 7700 Control flame signal voltage.**

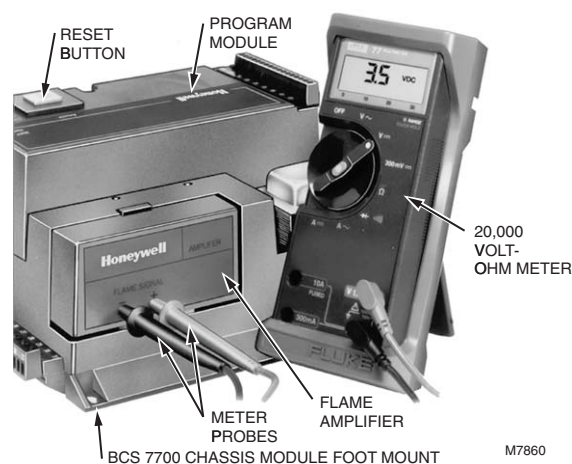

**PILOT TURNDOWN TEST**

If the flame rod is used to prove a pilot flame before the main fuel valve(s) can be opened, perform a Pilot Turndown Test. Follow the procedures in the Instructions for the appropriate flame safeguard control, and in the burner manufacturer's instructions.

**Fig. 7—Measuring the 7800 SERIES Control flame signal voltage.**

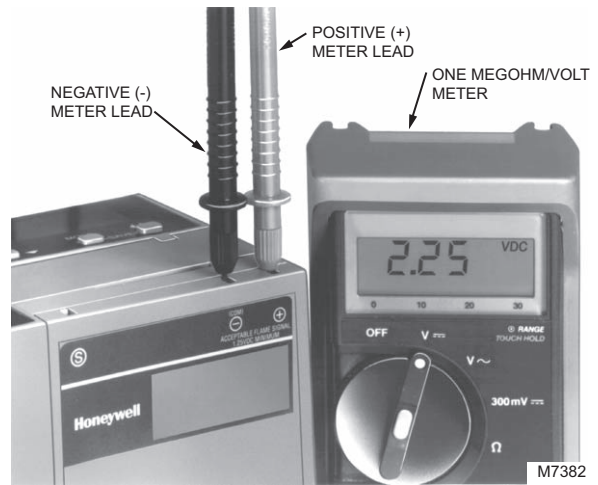

**Honeywell**

*Helping You Control Your World*

**Residential and Building Controls Division**  
Honeywell Inc.  
1985 Douglas Drive North  
Golden Valley, MN 55422

**Residential and Building Controls Division**  
Honeywell Limited—Honeywell Limitée  
740 Ellesmere Road  
Scarborough, Ontario  
M1P 2V9

